

DC TO AC

POWER INVERTER

User's manual

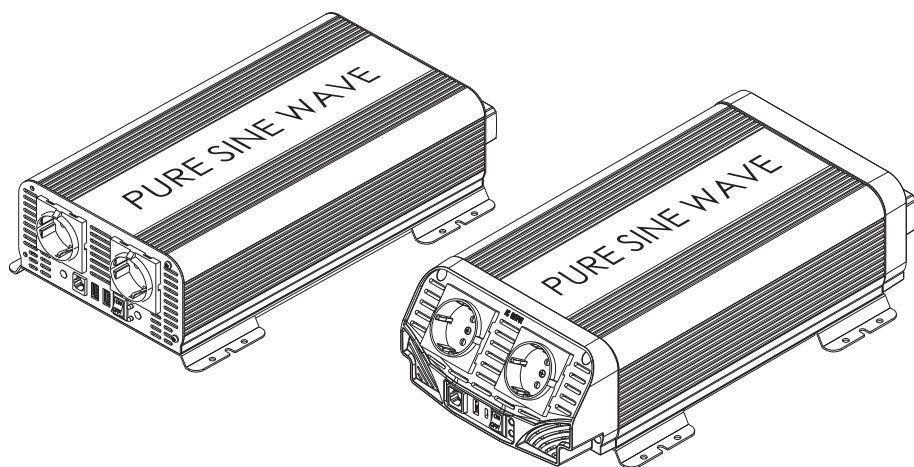
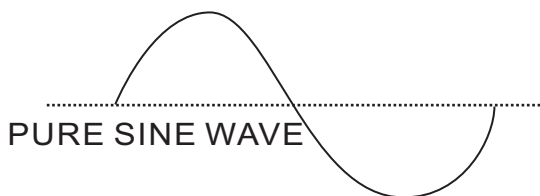

Applicable to DSU-Z & DSU-X series

Safety Instructions

1.General Safety Precautions

Warning : Before using the Inverter, read the safety instructions.

- 1-1.Do not expose the inverter to rain, snow, spray or dust. To reduce the risk of fire hazard, do not cover or obstruct the ventilation openings and do not install the inverter in a zero-clearance area.
- 1-2.To avoid the risk of fire and electric shock, make sure that the existing wiring is in good electrical condition, and the wire size is not undersized.
- 1-3.This equipment contains components which can produce arcs or sparks. To prevent fire or explosion do not install in area containing batteries or flammable materials or in location which require ignition protection equipment.
- 1-4.The inverter incorporates standard AC short circuit protection. But depending on the user scenario, the AC output of the inverter may require user to install breaker or fuse.
- 1-5.An over current protection device is suggested to be added for AC Output Circuit during installation.
- 1-6.The following precautions should be taken when working with the inverter :
 - Step 1. Remove watches, rings, or other metal objects
 - Step 2. Use tools with insulated handles
 - Step 3. Wear rubber gloves and boots

Safety Instructions

2. Other Safety Notes

2-1. Upon receipt, check if the carton box in good condition.

If you have found any damage on the carton box please notify the dealer which you purchased this unit.

2-2. Do not operate near water or in excessive humidity.

2-3. Do not open or disassemble the inverter, otherwise no warranty.

2-4. The DC side connections should be firm and tight.

2-5. Do not drop a metal tool on the battery. The spark or short-circuit occurred in the battery or other electrical part may cause an explosion.

2-6. Install the inverter in a well-ventilated area. Do not block the air vents of the front, back and bottom sides of the unit.

Wiring: Adequate input power must be supplied to the inverter for proper use; correct wiring sizes must be ensured.

2-7. Mounted area must be flat, otherwise heat dissipation of cooling fan will be affected.

2-8. Do not operate the inverter close to combustible gas or open fire.

2-9. Do not operate appliances that may feed power back into the inverter.

2-10. Temperature: The inverter should be operated in an ambient temperature range of $-15^{\circ}\text{C} \sim 25^{\circ}\text{C}$, otherwise the output efficiency may be affected. Air flow to the inverter must not be blocked.

2-11. In order to keep a long lifespan of the inverter, recommended load power is within 85% of the rated output power of the inverter.

Structural Drawings

DSU-Z Series DSU-300Z,DSU-600Z

- ① AC socket ;*
- ② Power (green);
- ③ Fault (red) ;
- ④ USB port;
- ⑤ On/Off switch ;
- ⑥ DC input “ + ” (red);
- ⑦ DC input “ - ” (black);
- ⑧ Fan;
- ⑨ Grounding;
- ⑩ LCD Display (if available);

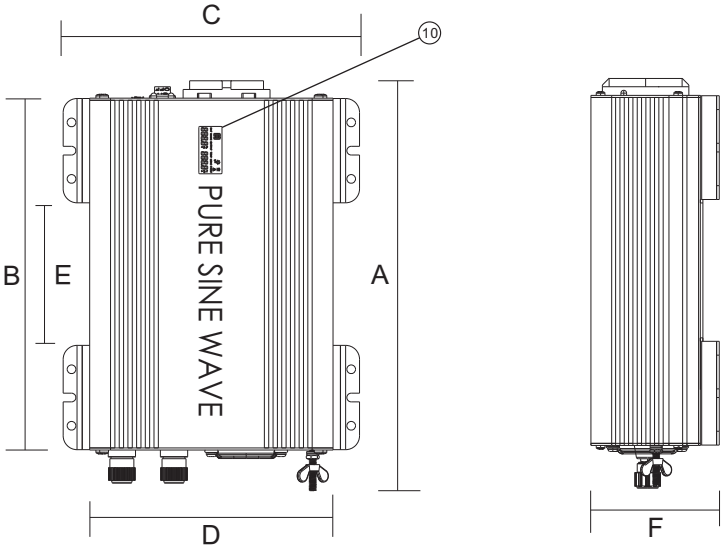
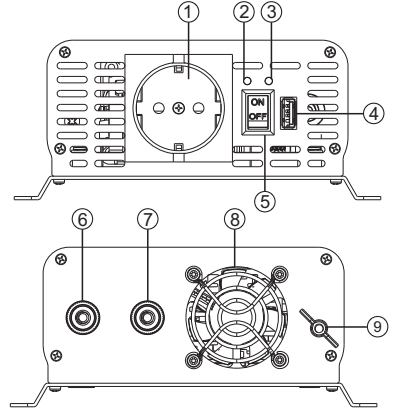

MODEL	A (mm)	B (mm)	C (mm)	D (mm)	E (mm)	F(mm)
300W	236	202	171	140	82	74
600W	267	232	171	140	112	74

 *Note: The type of the AC socket depends on the actual product. The drawings is for reference only.

Structural Drawings

DSU-Z Series

DSU-1K0Z, DSU-1K5Z, DSU-2K0ZA, DSU-3K0ZA

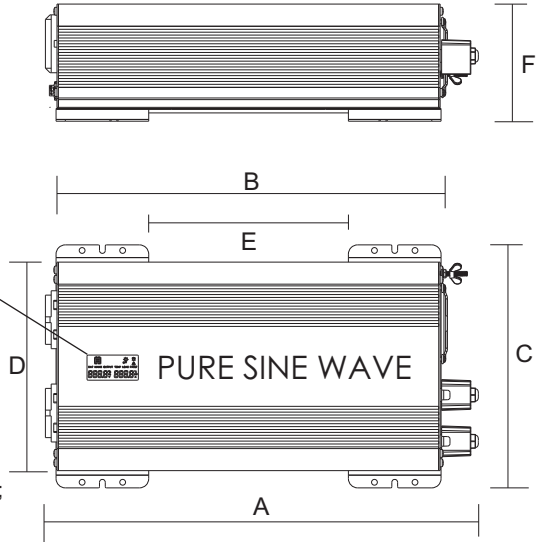
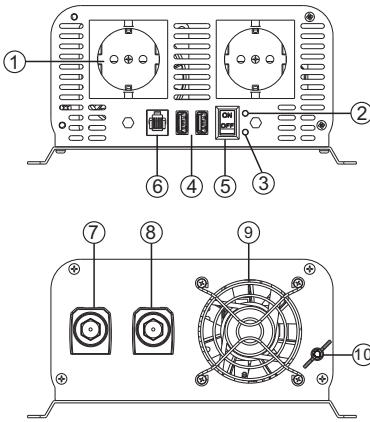

- ① AC socket ;*
- ② Power (green);
- ③ Fault (red) ;
- ④ USB port;
- ⑤ On/Off switch ;
- ⑥ Remote Port;
- ⑦ DC input " + " (red);
- ⑧ DC input " - " (black);
- ⑨ Fan;
- ⑩ Grounding;
- ⑪ LCD Display (if available);

MODEL	A (mm)	B (mm)	C (mm)	D (mm)	E (mm)	F(mm)
1000W	374	332	210	180	173	101
1500W	374	332	210	180	173	101
2000W	385	340	250	221.5	183	100
3000W	427	382	250	221.5	225	100

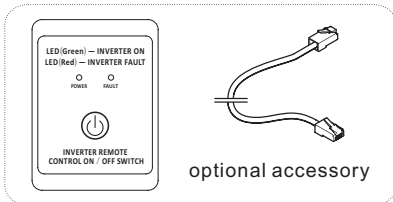

▲ Remote Control Usage : Please keep "OFF" position for switch of inverter, otherwise remote control function is invalid.

Status instruction for LED light of Remote Control Panel :

Function	LED light	
	Red	Green
Input under voltage alarm	OFF	ON
Input under voltage shut down	ON	ON
Input over voltage shut down	ON	ON
Over load shut down	ON	ON
Over temperature shut down	ON	ON
Output short - circuit	ON	ON

*Note: The type of the AC socket depends on the actual product. The drawings is for reference only.

Structural Drawings

DSU-Z Series DSU-2K0Z, DSU-2K5Z, DSU-3K0Z

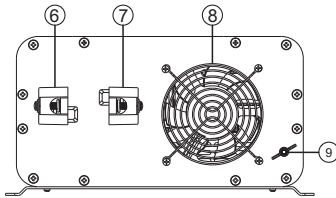
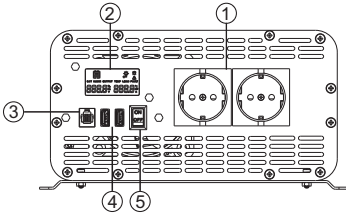

- ① AC socket ;*
- ② LCD Display ;
- ③ Remote Port ;
- ④ USB port ;
- ⑤ On/Off switch ;
- ⑥ DC input " + " (red) ;
- ⑦ DC input " - " (black) ;
- ⑧ Fan ;
- ⑨ Grounding ;

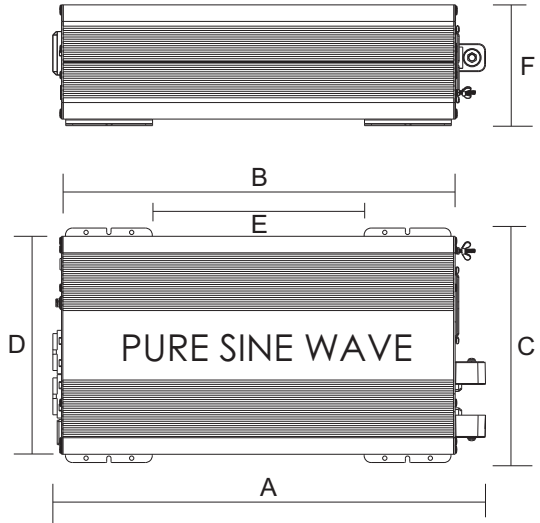

MODEL	A (mm)	B (mm)	C (mm)	D (mm)	E (mm)	F(mm)
2000W	498	450	270	251	244	139
2500W	498	450	270	251	244	139
3000W	498	450	270	251	244	139

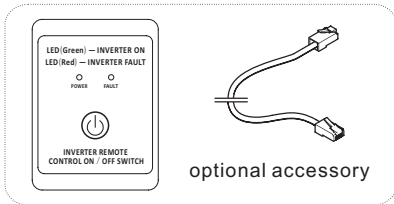

▲ Remote Control Usage : Please keep "OFF" position for switch of inverter, otherwise remote control function is invalid.

Status instruction for LED light of Remote Control Panel :

Function	LED light	
	Red	Green
Input under voltage alarm	ON	ON
Input under voltage shut down	Flickering	ON
Input over voltage shut down	Flickering	ON
Over load shut down	Flickering	ON
Over temperature shut down	Flickering	ON
Output short - circuit	Flickering	ON

*Note: The type of the AC socket depends on the actual product. The drawings is for reference only.

Structural Drawings

DSU-X Series DSU-300X,DSU-600X

- ① AC socket ;*
- ② Power (green);
- ③ Fault (red) ;
- ④ USB port;
- ⑤ On/Off switch ;
- ⑥ DC input “ + ” (red);
- ⑦ DC input “ - ” (black);
- ⑧ Fan;
- ⑨ Grounding;
- ⑩ LCD Display (if available);

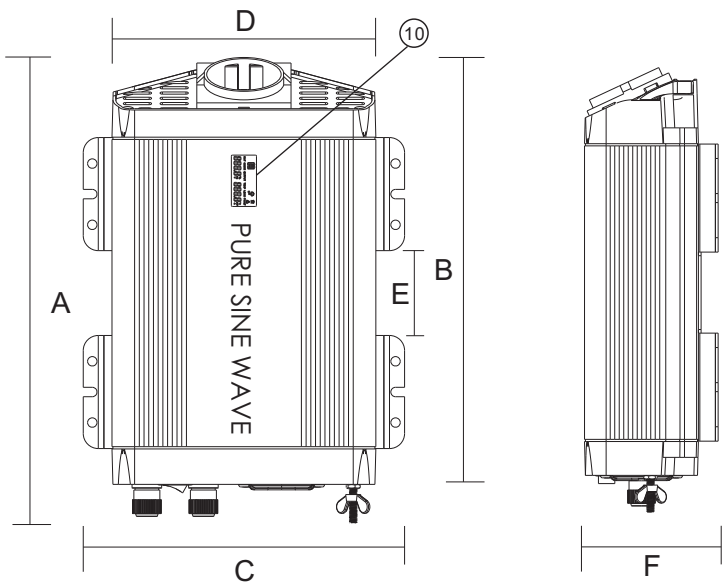
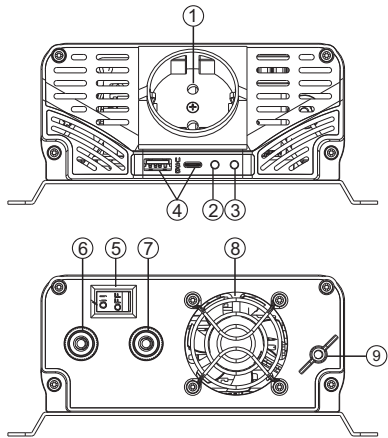

MODEL	A (mm)	B (mm)	C (mm)	D (mm)	E (mm)	F(mm)
300W	253	229	171	140	82	74
600W	292	262	171	140	95	74

 *Note: The type of the AC socket depends on the actual product. The drawings is for reference only.

Structural Drawings

DSU-X Series DSU-1K0X,DSU-1K5X

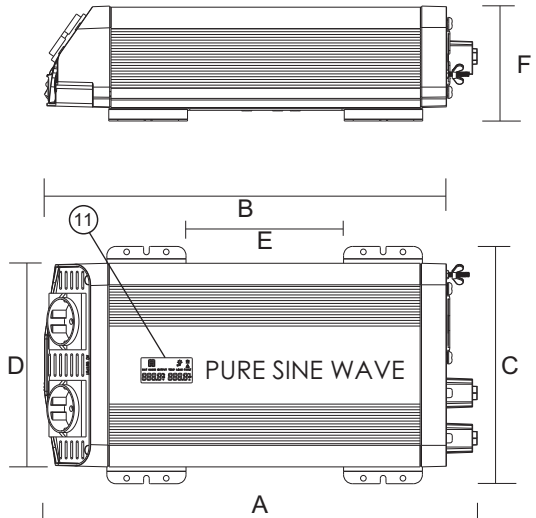
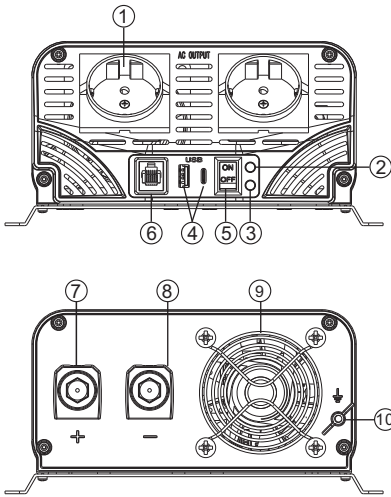

- ① AC socket ;*
- ② Power (green);
- ③ Fault (red) ;
- ④ USB port;
- ⑤ On/Off switch ;
- ⑥ Remote Port;
- ⑦ DC input “ + ” (red);
- ⑧ DC input “ - ” (black);
- ⑨ Fan;
- ⑩ Grounding;
- ⑪ LCD Display (if available);

MODEL	A (mm)	B (mm)	C (mm)	D (mm)	E (mm)	F (mm)
1000W	384	357	210	180	139.3	102.1
1500W	384	357	210	180	139.3	102.1

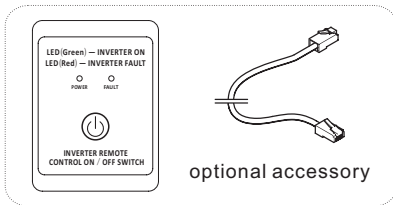

▲ Remote Control Usage : Please keep "OFF" position for switch of inverter, otherwise remote control function is invalid.

Status instruction for LED light of Remote Control Panel :

Function	LED light	
	Red	Green
Input under voltage alarm	OFF	ON
Input under voltage shut down	ON	ON
Input over voltage shut down	ON	ON
Over load shut down	ON	ON
Over temperature shut down	ON	ON
Output short - circuit	ON	ON

*Note: The type of the AC socket depends on the actual product. The drawings is for reference only.

Structural Drawings

DSU-X Series DSU-2K0XA, DSU-3K0XA

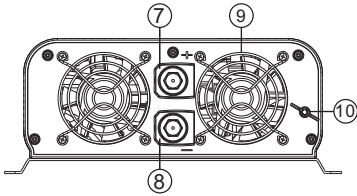
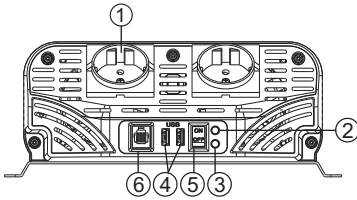

- ① AC socket ;*
- ② Power (green);
- ③ Fault (red) ;
- ④ USB port;
- ⑤ On/Off switch ;
- ⑥ Remote Port;
- ⑦ DC input “ + ” (red);
- ⑧ DC input “ - ” (black);
- ⑨ Fan;
- ⑩ Ground;
- ⑪ LCD Display
(if available);

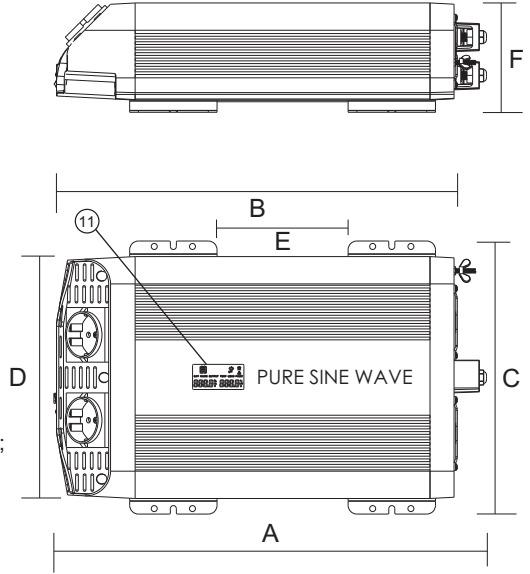

MODEL	A (mm)	B (mm)	C (mm)	D (mm)	E (mm)	F(mm)
2000W	406	364	250	222	130	100.1
3000W	448	406	250	222	172	100.1

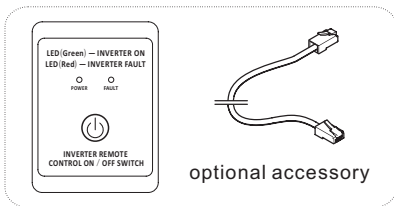

▲ Remote Control Usage : Please keep "OFF" position for switch of inverter, otherwise remote control function is invalid.

Status instruction for LED light of Remote Control Panel :

Function	LED light	
	Red	Green
Input under voltage alarm	OFF	ON
Input under voltage shut down	ON	ON
Input over voltage shut down	ON	ON
Over load shut down	ON	ON
Over temperature shut down	ON	ON
Output short - circuit	ON	ON

*Note: The type of the AC socket depends on the actual product. The drawings is for reference only.

Structural Drawings

DSU-X Series DSU-2K0X, DSU-2K5X, DSU-3K0X

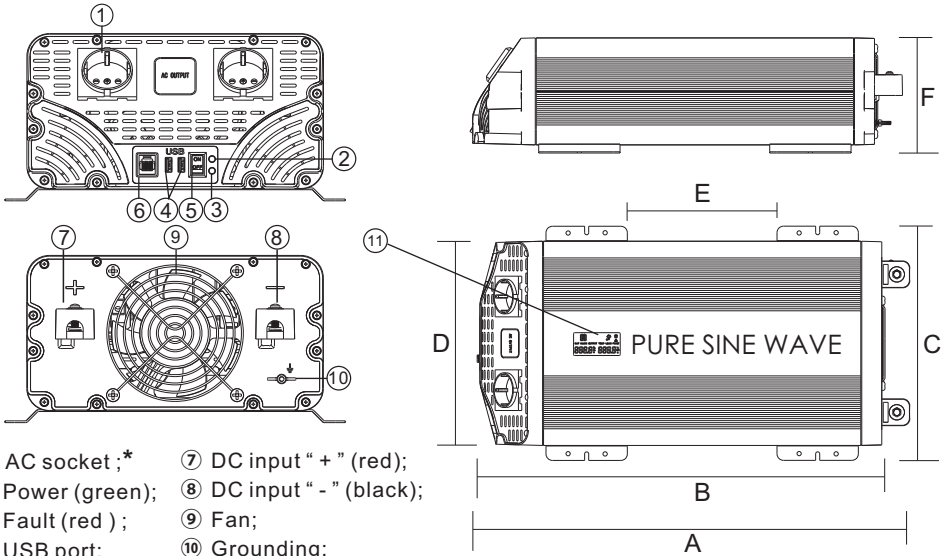

- ① AC socket ; *
- ② Power (green);
- ③ Fault (red) ;
- ④ USB port;
- ⑤ On/Off switch ;
- ⑥ Remote Port;
- ⑦ DC input “ + ” (red);
- ⑧ DC input “ - ” (black);
- ⑨ Fan;
- ⑩ Grounding;
- ⑪ LCD Display;

MODEL	A (mm)	B (mm)	C (mm)	D (mm)	E (mm)	F(mm)
2000W	532	494	287.9	251	184	141.5
2500W	532	494	287.9	251	184	141.5
3000W	532	494	287.9	251	184	141.5

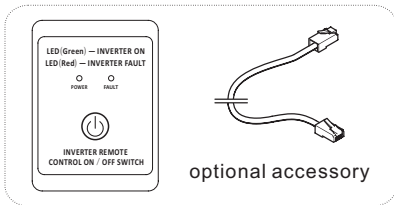

▲ Remote Control Usage : Please keep "OFF" position for switch of inverter, otherwise remote control function is invalid.

Status instruction for LED light of Remote Control Panel :

Function	LED light	
	Red	Green
Input under voltage alarm	ON	ON
Input under voltage shut down	Flickering	ON
Input over voltage shut down	Flickering	ON
Over load shut down	Flickering	ON
Over temperature shut down	Flickering	ON
Output short - circuit	Flickering	ON

*Note: The type of the AC socket depends on the actual product. The drawings is for reference only.

Installation & Operational specification

1.Installation

Warning! Make sure that all the DC connections are tight.

Loose connections will cause overheating and potential hazard.

Also, only use high quality copper wire and keep the cable in suitable length.

VENTILATION

To allow an effective heat dissipation, power inverter must be positioned as the way shown in right figure, so that cooling fan can work properly.

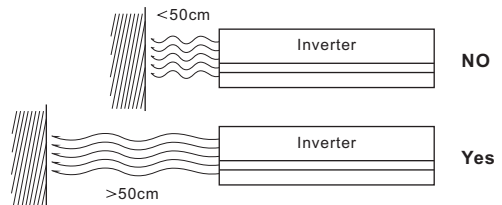

2.Operational specification

2-1. Before connecting the battery, the inverter switch must be at “OFF”.

2-2. To connect the loads:

2-2-1. Calculate the total power consumption of the output load.

Make sure that the total power consumption does not exceed the rated power.

If the total power consumption over the rated power of the inverter, remove the non-critical loads until the total power consumption is less than the rated power.

2-2-2. The load must be at OFF status before it is connected to the inverter.

2-2-3. According to the various power of different load, turn on the load in turns from large to small.

2-2-4. After the first load starts up properly, turn on the next load

2-2-5. After use, first turn off the load, then turn off the inverter, and finally disconnect the connection.

Electrical Specification

Specification 1:

Model	DSU-300Z DSU-300X	DSU-600Z DSU-600X	DSU-1K0Z DSU-1K0X	DSU-1K5Z DSU-1K5X
Input	Rated input voltage	DC 13V (@12V Inverter) , DC 26V (@24V Inverter)		
	Operating voltage range	DC 11V-15V (@12V Inverter) , DC 22V-30V (@24V Inverter)		
Output	No-load output voltage	AC 230V +/- 10V (@ Rated input voltage), AC 115V +/- 10V (@ Rated input voltage)		
	Load output voltage	AC 210V ~ AC 240V (@ Rated input voltage), AC 115V +/- 10V (@ Rated input voltage)		
	Output frequency	50Hz +/- 0.5Hz, 60Hz +/- 0.5Hz		
	USB Output	DC 5V, 2100mA or other ,Type-C:18W Max. (if available)		
Continuous power	300W	600W	1000W	1500W
	600W	1200W	2000W	3000W
Output Wave	Pure sine wave			
Max Efficiency				
No load current	12V Input	≤1.0A	≤1.1A	≤1.3A
	24V Input	≤0.4A	≤0.6A	≤0.7A
Low voltage	Input Low-Voltage Alarm	DC 10.5V +/- 0.3V (@12V Inverter) ,DC 21V +/- 0.4V (@24V Inverter)		
	Input Low-Voltage Shut Down	DC 9.5V +/- 0.3V (@12V Inverter) ,DC 19V +/- 0.4V (@24V Inverter)		
Over voltage	Low-Voltage Recovery Voltage	12V Inverter : When the input voltage rises to 12V +/- 0.3V, the inverter will automatically resume operation. 24V Inverter : When the input voltage rises to 24V +/- 0.4V, the inverter will automatically resume operation.		
	Input Over Voltage Shut Down	DC 16V +/- 0.3V (@12V Inverter) ,DC 32V +/- 0.4V (@24V Inverter)		
Over load	Over-voltage Recovery Voltage	12V Inverter : When the input voltage drops to 14V +/- 0.3V, the inverter will automatically resume operation. 24V Inverter : When the input voltage drops to 28V +/- 0.4V, the inverter will automatically resume operation.		
	Over-load protection	Yes(360-400W)	Yes(650-750W)	Yes(1100-1250W) Yes(1550-1800W)
Overload Recovery	Reduce the load to the rated power range. Restart inverter recovery work. Or Wait 1-3 minutes for the inverter to recover automatically.			
Over Temperature protection	Yes			
Over Temperature Recovery	When the temperature inside the inverter decreases to the set point, the inverter will back to work automatically.			
Short circuit	Output Short Circuit protection	Yes		
Reverse protection	Short Circuit Recovery	After troubleshooting, restart the inverter by manual to resume work. Reverse connection will blow the fuse, fuse replacement with the same specifications can fix the inverter; Reverse connection will cause irreparable damage to the inverter!		
Other	The Best Working Temperature	-15°C ~ 25°C		
	Fuse (@12V Inverter)	40A*1	35A*2	35A*4 40A*4
Remote control	Fuse (@24V Inverter)	20A*1	20A*2	20A*4 25A*4
	Cooling method	By Fan (temperature controlled)		
LCD display information (if available)	Input voltage , Load power , Output frequency , Output current , Battery power , Fault code (E0: Low volt, E1: Over volt, E2: Over temp, E3: Over load, E4: Output short circuit)			
	Remote control	Without Optional , RJ12 port , 6m cable		

Electrical Specification

Specification 2:

Input	Model	DSU-2K0Z ,DSU-2K0X DSU-2K0ZA ,DSU-2K0XA	DSU-2K5Z DSU-2K5X	DSU-3K0Z ,DSU-3K0X DSU-3K0ZA ,DSU-3K0XA
Rated input voltage	Rated input voltage range	DC 13V (@12V inverter) , DC 26V (@24V inverter)		
	Operating voltage range	DC 11V-15V (@12V inverter) , DC 22V-30V (@24V inverter)		
Output	No-load output voltage	AC 230V +/- 10V (@ Rated input voltage) , AC 115V +/- 10V (@ Rated input voltage)		
	Load output voltage	AC 210V ~ AC 240V (@ Rated input voltage) , AC 115V +/- 10V (@ Rated input voltage)		
USB Output	Output frequency	50Hz +/- 0.5Hz, 60Hz +/- 0.5Hz		
	USB Output	DC 5V, 2100mA or other ,Type-C:18W Max.(if available)		
Continuous power	2000W	3000W		
	4000W	6000W		
Peak power	2000W	3000W		
	4000W	6000W		
Output Wave	Output Wave	Pure sine wave		
	Max Efficiency	≥85%		
No load current	12V Input	≤1.6A	≤2.0A	≤2.0A
	24V Input	≤0.8A	≤1.0A	≤1.0A
Low voltage	Input Low-Voltage Alarm	DC 10.5V +/- 0.3V (@12V inverter) , DC 21V +/- 0.4V (@24V inverter)		
	Input Low-Voltage Shut Down	DC 9.5V +/- 0.3V (@12V inverter) , DC 19V +/- 0.4V (@24V inverter)		
Over voltage	Low-Voltage Recovery Voltage	12V Inverter: When the input voltage rises to 12V +/- 0.3V, the inverter will automatically resume operation. 24V Inverter: When the input voltage rises to 24V +/- 0.4V, the inverter will automatically resume operation.		
	Input Over Voltage Shut Down	DC 16V +/- 0.3V (@12V inverter) , DC 32V +/- 0.4V (@24V inverter)		
Over load	Over-voltage Recovery Voltage	12V Inverter: When the input voltage drops to 14V +/- 0.3V, the inverter will automatically resume operation. 24V Inverter: When the input voltage drops to 28V +/- 0.4V, the inverter will automatically resume operation.		
	Over-load protection	Yes(2150-2300W)	Yes(2650-2850W)	Yes(3150-3400W)
Over temp	Overload Recovery	Reduce the load to the rated power range. Restart inverter recovery work. Or Wait 4-6 minutes for the inverter to recover automatically.		
	Over Temperature protection	Yes		
Short circuit	Over Temperature Recovery	When the temperature inside the inverter decreases to the set point, the inverter will back to work automatically.		
	Output Short Circuit protection	Yes		
Reverse protection	Short Circuit Recovery	After troubleshooting, restart the inverter by manual to resume work.		
	Reverse protection	Reverse connection will blow the fuse, fuse replacement with the same specifications can fix the inverter; Reverse connection will cause irreparable damage to the inverter!		
Other	The Best Working Temperature	-15℃ ~ 25℃		
	Fuse (@12V inverter)	35A*7	30A*10	35A*10
Remote control	Fuse (@24V inverter)	35A*4	25A*7	30A*7
	Cooling method	By Fan (temperature controlled)		
LCD display information (if available)	Input voltage , Load power , Output frequency ,Output current , Battery power , Fault code			
	(E0: Low volt, E1: Overvolt, E2: Over temp, E3: Over load, E4: Output short circuit)			
Optional , RI12 port , 6m cable	Optional , RI12 port , 6m cable			

Troubleshooting

For : DSU-300Z,DSU-600Z,DSU-1K0Z,DSU-1K5Z,DSU-2K0ZA,DSU-3K0ZA
DSU-300X,DSU-600X,DSU-1K0X,DSU-1K5X,DSU-2K0XA,DSU-3K0XA

Function	State description					Restart work method
	LCD display (if available)	Green LED	Red LED	Alarm	AC output	
Input under voltage alarm		ON	OFF	Yes Di.....	YES	Stop using , recharge the battery. Or replace new batteries
Input under voltage shut down		ON	ON	Yes Di...Di...	NO	Stop using, recharge the battery. Or replace new batteries
Input over voltage shut down		ON	ON	Yes Di...Di...	NO	Stop using, check if the battery is damaged. Or replace new batteries
Over load shut down		ON	ON	Yes Di...Di...	NO	Reduce the load to the rated power range. Restart inverter manually. Or Wait for 1-3 minutes to recover automatically.
Over temperature shut down		ON	ON	Yes Di...Di...	NO	Stop using, cool the inverter and wait for the temperature to drop before using.
Output short-circuit		ON	ON	Yes Di...Di...	NO	Stop using , check the connecting cable and loads. Restart after troubleshooting.

For : DSU-2K0Z,DSU-2K5Z,DSU-3K0Z,DSU-2K0X,DSU-2K5X,DSU-3K0X

Function	State description					Restart work method
	LCD display (if available)	Green LED	Red LED	Alarm	AC output	
Input under voltage alarm		ON	OFF	Yes Di.....	YES	Stop using , recharge the battery. Or replace new batteries
Input under voltage shut down		Flickering	ON	Yes Di...Di...	NO	Stop using, recharge the battery. Or replace new batteries
Input over voltage shut down		Flickering	ON	Yes Di...Di...	NO	Stop using, check if the battery is damaged. Or replace new batteries
Over load shut down		Flickering	ON	Yes Di...Di...	NO	Reduce the load to the rated power range. Restart inverter manually. Or Wait for 4-6 minutes to recover automatically.
Over temperature shut down		Flickering	ON	Yes Di...Di...	NO	Stop using, cool the inverter and wait for the temperature to drop before using.
Output short-circuit		Flickering	ON	Yes Di...Di...	NO	Stop using , check the connecting cable and loads. Restart after troubleshooting.

Voltage & temperature performance

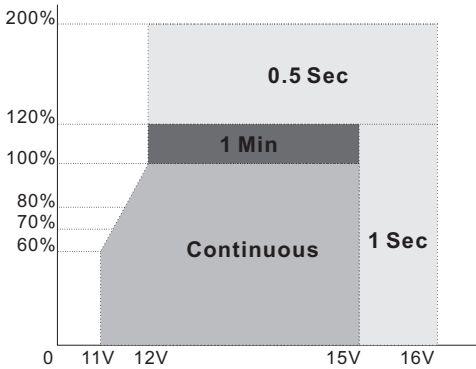

Figure 1 : Output power **VS** input voltage

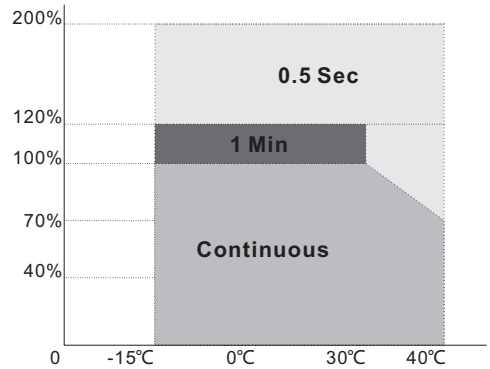

Figure 2 : Output power **VS** temperature

Maintenance

1. Make sure the fan vents are not blocked.
2. Use a vacuum cleaner to remove any dust from the fan area.
3. When cleaning the case or front panel, use a soft and dry cloth only.
If the case or front panel is very dirty, clean with neutral and non-abrasive detergent. Do not use alcohol or ammonia based solutions.
4. Avoid any liquid or metal falling into the inverter.
5. Ensure the screws on the DC input terminal is tight, check if the inverter work indicator is correct.

Warning : Do not open or disassemble the inverter.

Attempting to do so may damage the inverter, may even cause electric shock or fire. If you need repair, please ask a professional or after-sales staff for help.

